



NeSSI

Wireless Sensor / Actuator Networking

March 7, 2001

John Crawford
VP, Business Development
Crossbow Technology, Inc.

Crossbow

INTELLIGENT
Sensors
CrossNet
WIRELESS



Background / Outline

- Crossbow: Five years in the digital sensor subsystem business
- New CrossNet Wireless sensor / actuator architecture
- *Sensor / Actuator “Node” uses open (Bluetooth) standard*
- *“Smart I/O (SI/O)” devices provide standards-based Plug-and-Play I/F to almost any sensor*

Crossbow

INTELLIGENT
Sensors
CrossNet
WIRELESS



Bluetooth Background

- Bluetooth: Norse king who brought together all of the warring factions
- Backed by Ericsson, Motorola, Microsoft and others
- Designed to replace IR port on PCs, etc. with RF approach
- Goal: PCs, PDAs, Cell phones, and peripherals can communicate easily.

Crossbow

INTELLIGENT
Sensors
CrossNet
WIRELESS

Bluetooth Overview

- Bluetooth RF Specification
 - » 2.4 GHz, Frequency hopping spread spectrum
 - » 721 kbps data rate
 - » 0 dBm (1 mW) nominal 10 meter range
 - » 20 dBm (100 mW) nominal 100 meter range
 - » Automatic retransmit until message receipt is verified (avoid lost data)
 - » Various data security levels can be implemented

Crossbow

INTELLIGENT
Sensors
CrossNet
WIRELESS

Bluetooth vs. Other Technologies

	Bluetooth	802.11b	Proprietary
Manufacturers	Ericsson, CSR, Motorola	Proxim; Aironet; Breezecom	Various
Frequency	2.4GHz	2.4GHz	49MHz, 900 MHz, 2.4GHz
Modulation	FHSS, 1600/sec	DSSS	FM;FH;DS
Datarate	720kb/sec	11Mb/sec	288kb/sec
Range	10m/100m	100m	Various
Robustness	Very secure	Secure	Various
Power	1mw/100mw	??	Various

Crossbow

INTELLIGENT
Sensors
CrossNet
WIRELESS



Basic Wireless Operation

- Inquiry – returns Bluetooth addresses of all devices within range
- Establish synchronized link—master/slave
- Establish a piconet – up to 7 slave devices in synchronized communication
- Establish a larger or more complex network
 - » Unlimited additional slave devices “parked”
 - » Master switches from piconet-piconet
- Hopping 1500/sec => effective latency O/M milliseconds (10s of milliseconds for larger networks)

Crossbow

ENT
Sensors
CrossNet
WIRELESS

Crossbow Node Architecture

300' or 30' Range

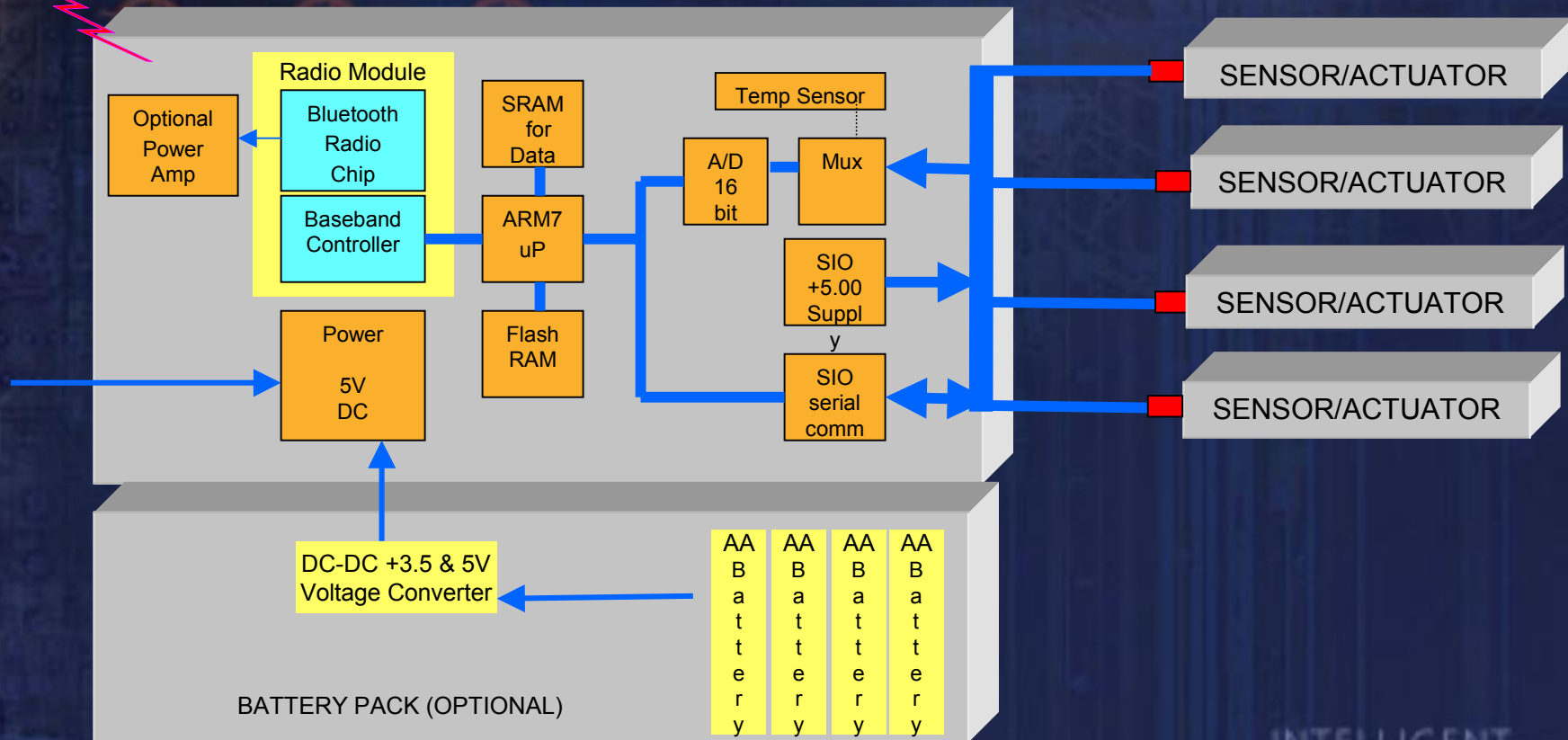

Crossbow

INTELLIGENT
Sensors
CrossNet
WIRELESS



Crossbow SoftSens Software

- Provide data to the user on whatever platform is desired (PC, laptop, PDA, web, etc.)
- Make data accessible to a variety of data acquisition and analysis packages (LabView, C++, Excel, Visual Basic, etc.)
- Manages all Bluetooth node operations (Inquiry, Connect, Piconet)
- Track nodes as they come into and out of radio range.
- Interrogate nodes for configuration and sensor information
- Transfer data.
- Configure operating modes and parameters.
- Establish common time stamp for all Nodes.
- Upload new Node and SIO code over radio.
- Allow SIOs to be user configured for TEDS.



Plug and Play Sensors / Actuators

- “Smart” Sensor I/O (SI/O):
 - » Make all sensors electrically consistent and smart
 - » Each sensor used interchangeably with CrossNet Bluetooth Wireless node
- Normalize raw analog signal for node input
 - » 4-20mA, DC Voltage, RTD, Thermocouple
- Store Electronic Data Sheet and Calibration Data for sensor
 - » Keep this info with the sensor in the SI/O
 - » Info includes: physical parameters, measurement range, desired engineering units, calibration information, user defined fields (sensor name, etc.)
 - » Based on IEEE 1451.2 TEDS/SCEDS standards
 - » Sensor can be added to measurement setup quickly and reliably

Crossbow

INTELLIGENT
Sensors
CrossNet
WIRELESS

SI/O Architecture

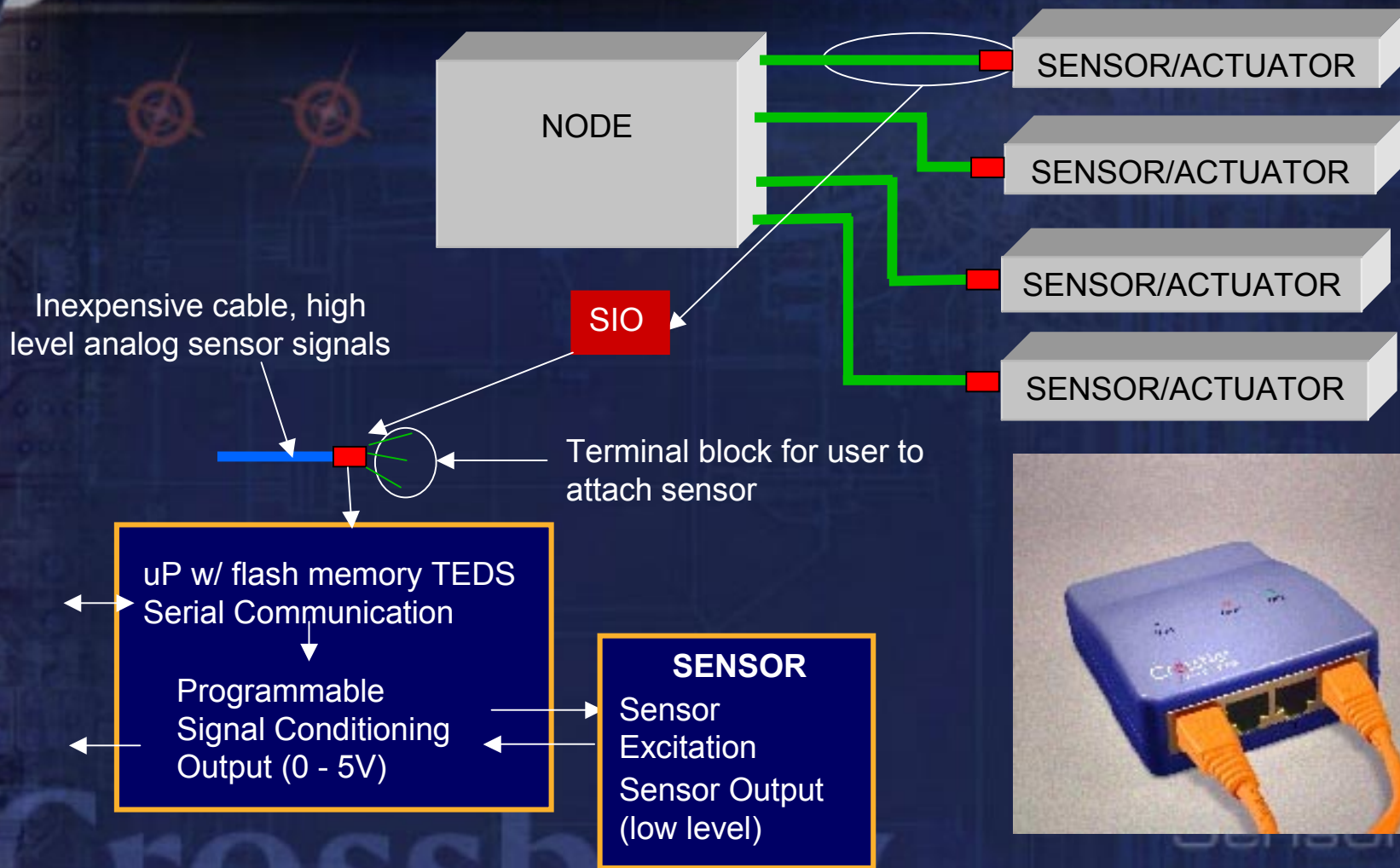

Typical Wireless I/O Application

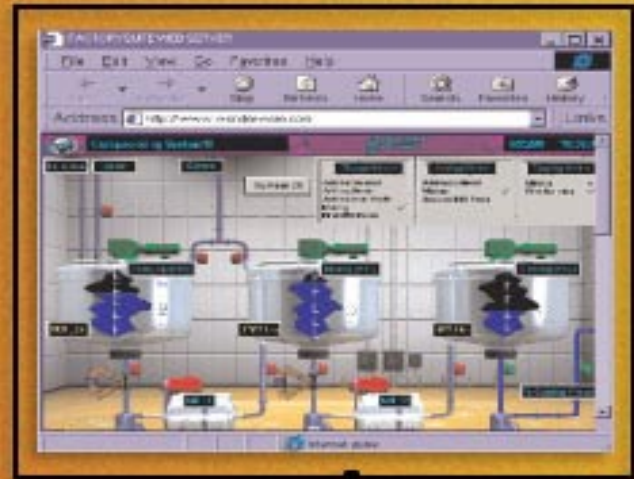

CrossNet Summary

- Open standards-based wireless sensor network
- Bluetooth-based wireless sensor/actuator “Node”
- Programmable “Smart” Sensor I/O device so most sensors and actuators can be included in the wireless network
- Software layer on Node and PC to manage wireless network, organize and communicate data, interface to popular data acquisition and control software
- *Next: how to adapt for NeSSI*

Crossbow

INTELLIGENT
Sensors
CrossNet
WIRELESS