

Applying Wireless / SI/O Architecture To NeSSI

March 7, 2001

**John Crawford
VP, Business Development
Crossbow Technology, Inc.**

Crossbow

INTELLIGENT
Sensors
CrossNet
WIRELESS

Wired S/A; Wireless IOC

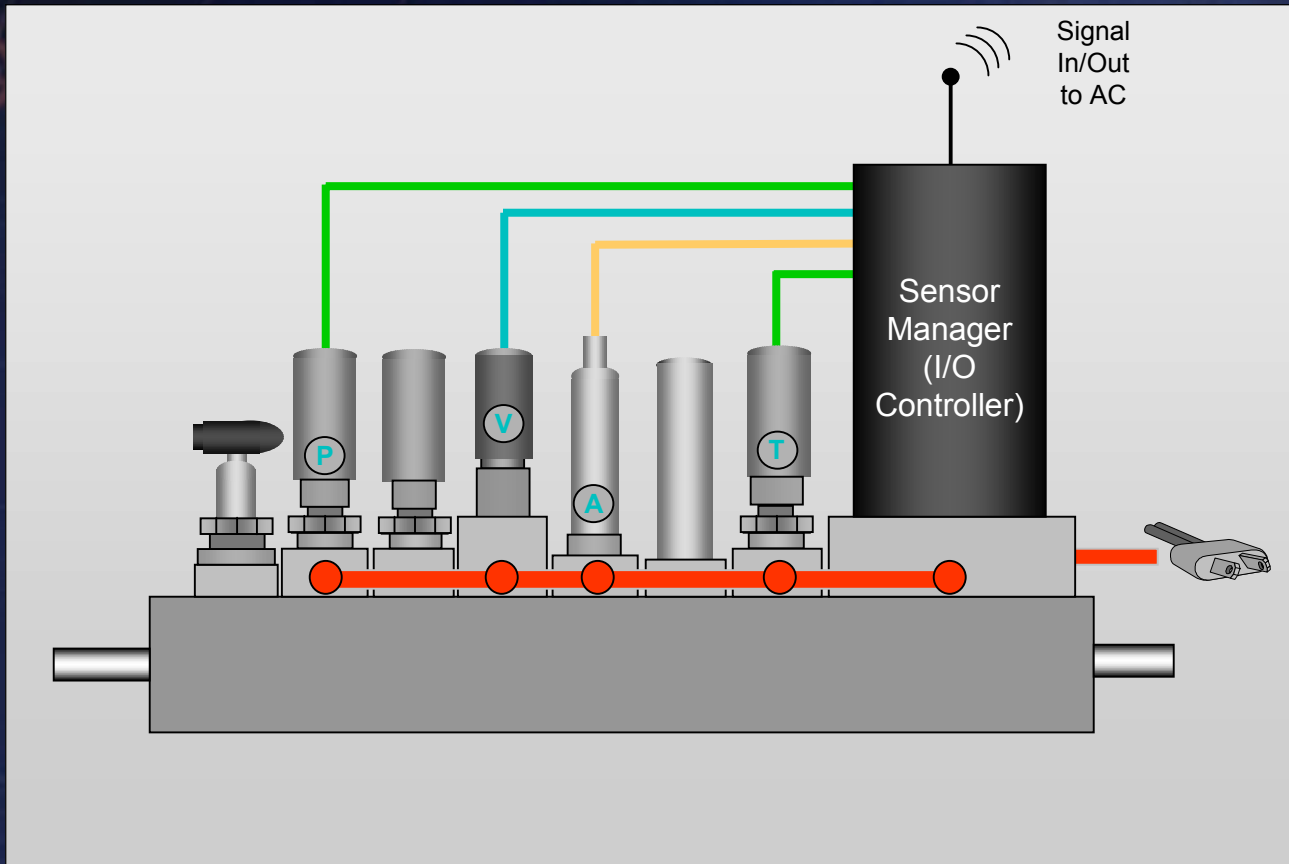

Wireless S/A; Wireless IOC

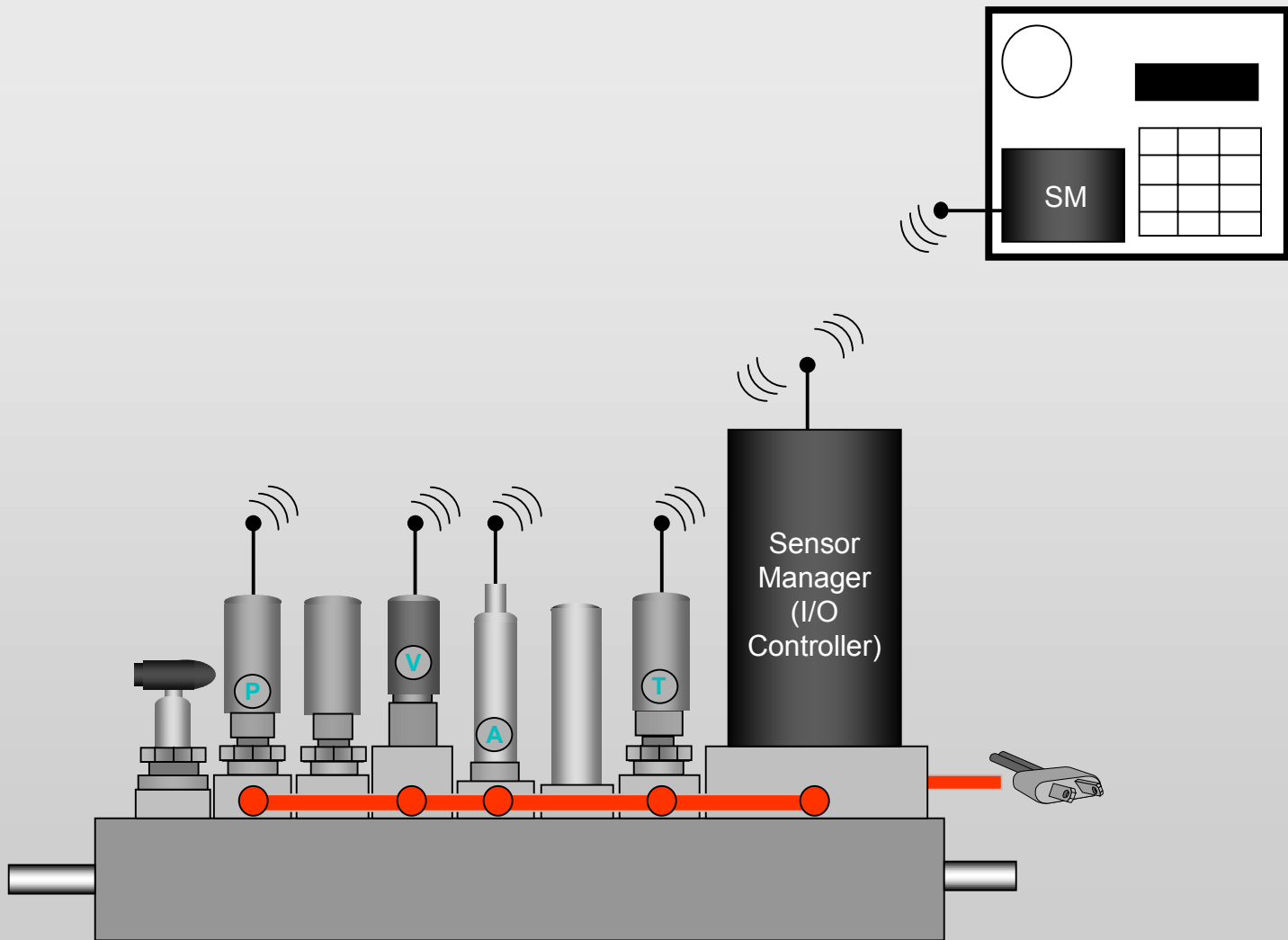

Node Architecture

300' or 30' Range

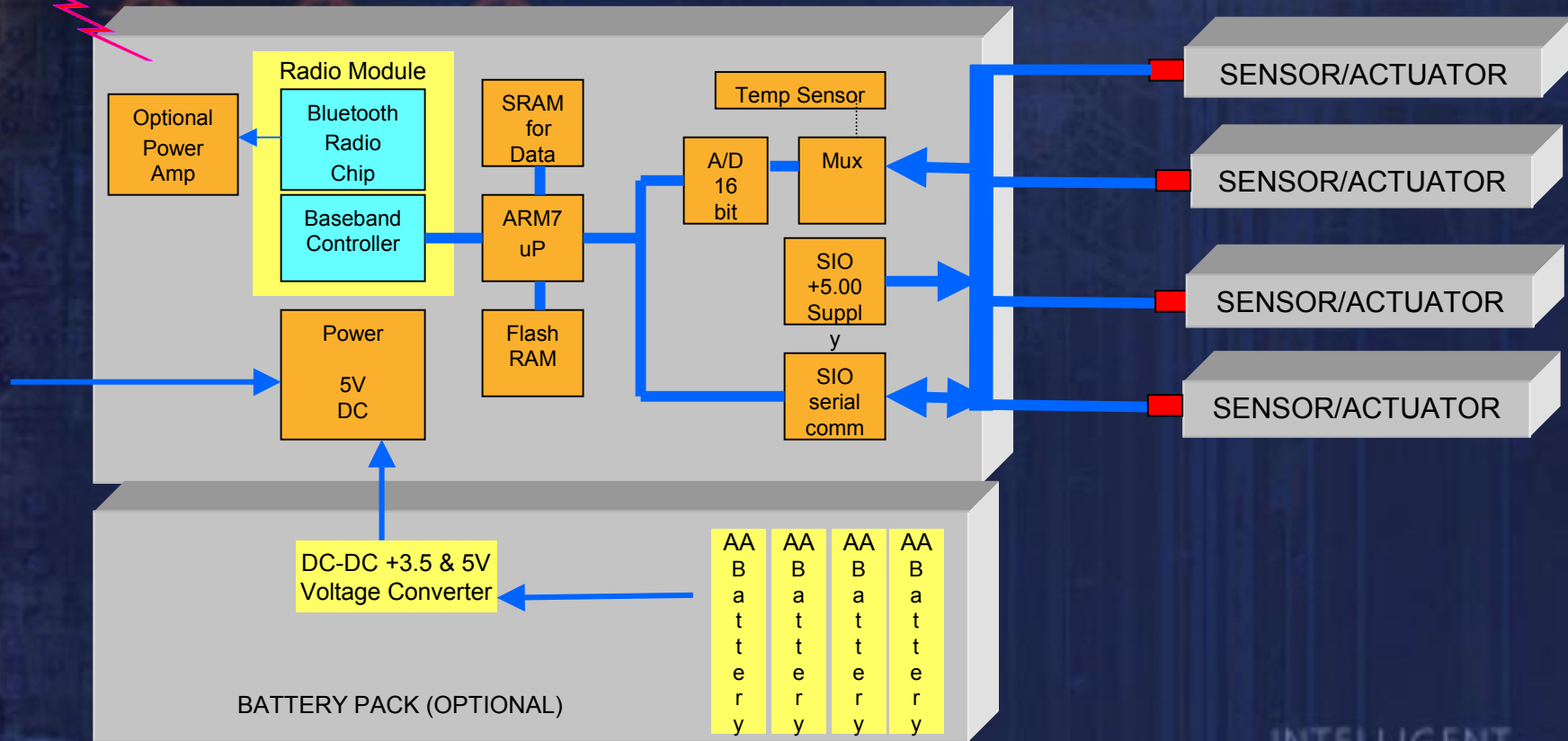

Crossbow

INTELLIGENT
Sensors
CrossNet
WIRELESS



CrossNet SoftSens Software

- Provide data to the user on whatever platform is desired (PC, laptop, PDA, web, etc.)
- Make data accessible to a variety of data acquisition and analysis packages (LabView, C++, Excel, Visual Basic, etc.)
- Manages all Bluetooth node operations (Inquiry, Connect, Piconet)
- Track nodes as they come into and out of radio range.
- Interrogate nodes for configuration and sensor information
- Transfer data.
- Configure operating modes and parameters.
- Establish common time stamp for all Nodes.
- Upload new Node and SIO code over radio.
- Allow SIOs to be user configured for TEDS.

SI/O Architecture

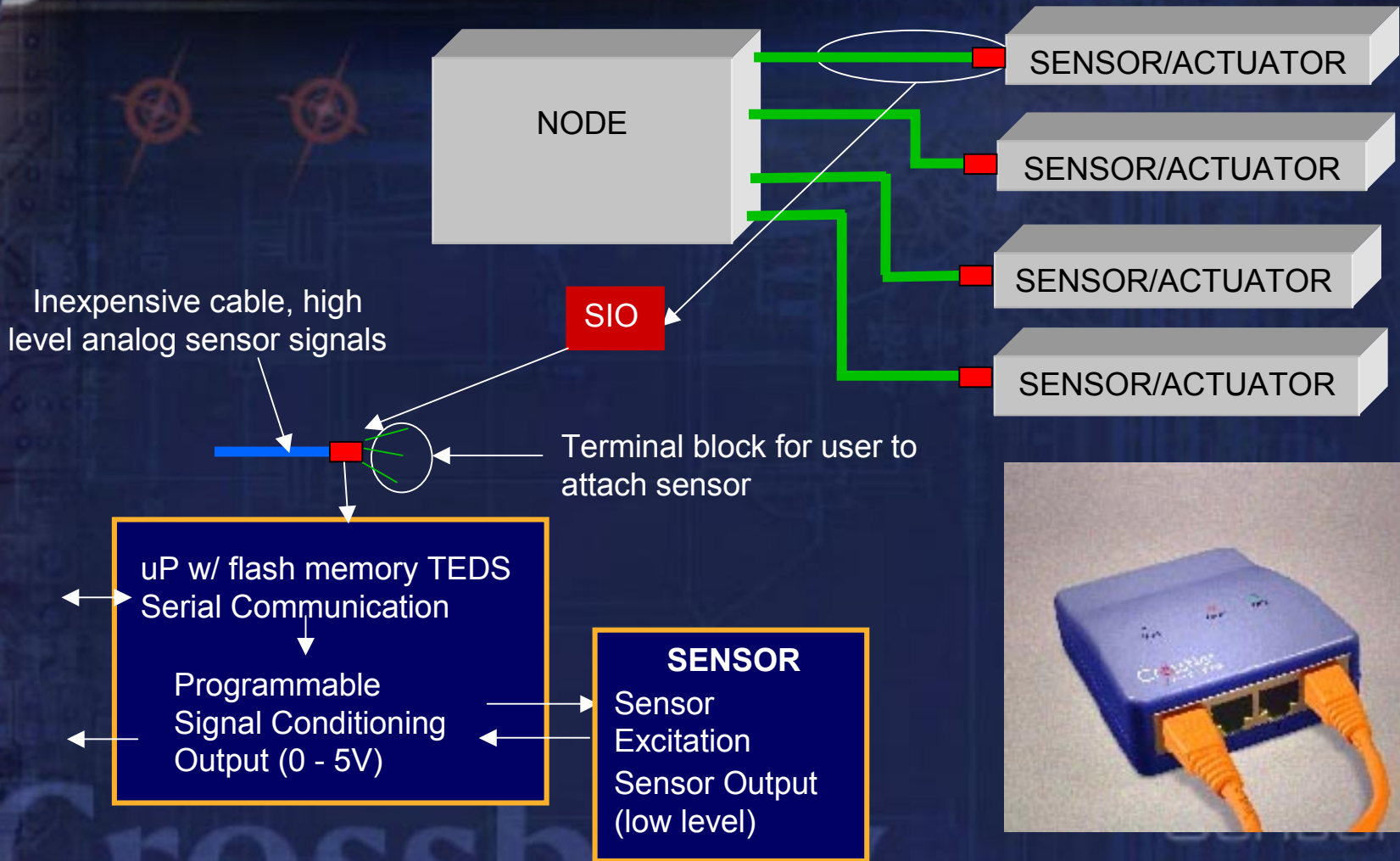

Single Channel Product

- Combine radio, processor, A/D, SIO, Transducer Electronic Data Sheet, software for small unit dedicated to single sensor

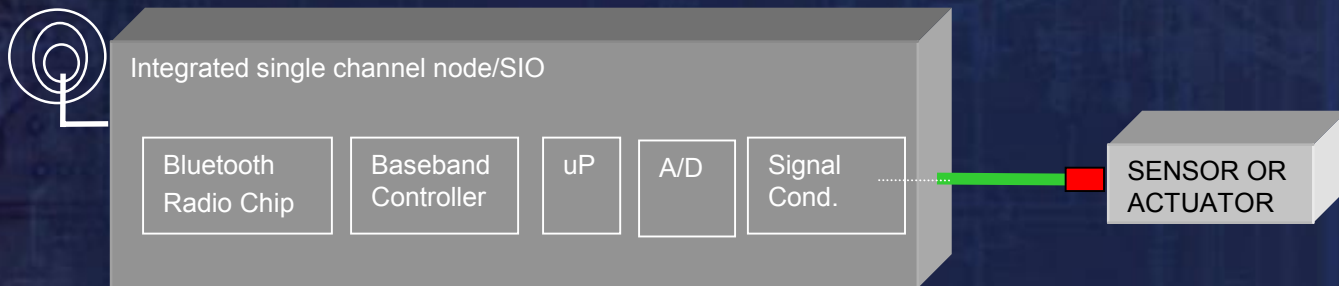

Crossbow

INTELLIGENT
Sensors
CrossNet
WIRELESS

Wireless S/A; Wireless IOC

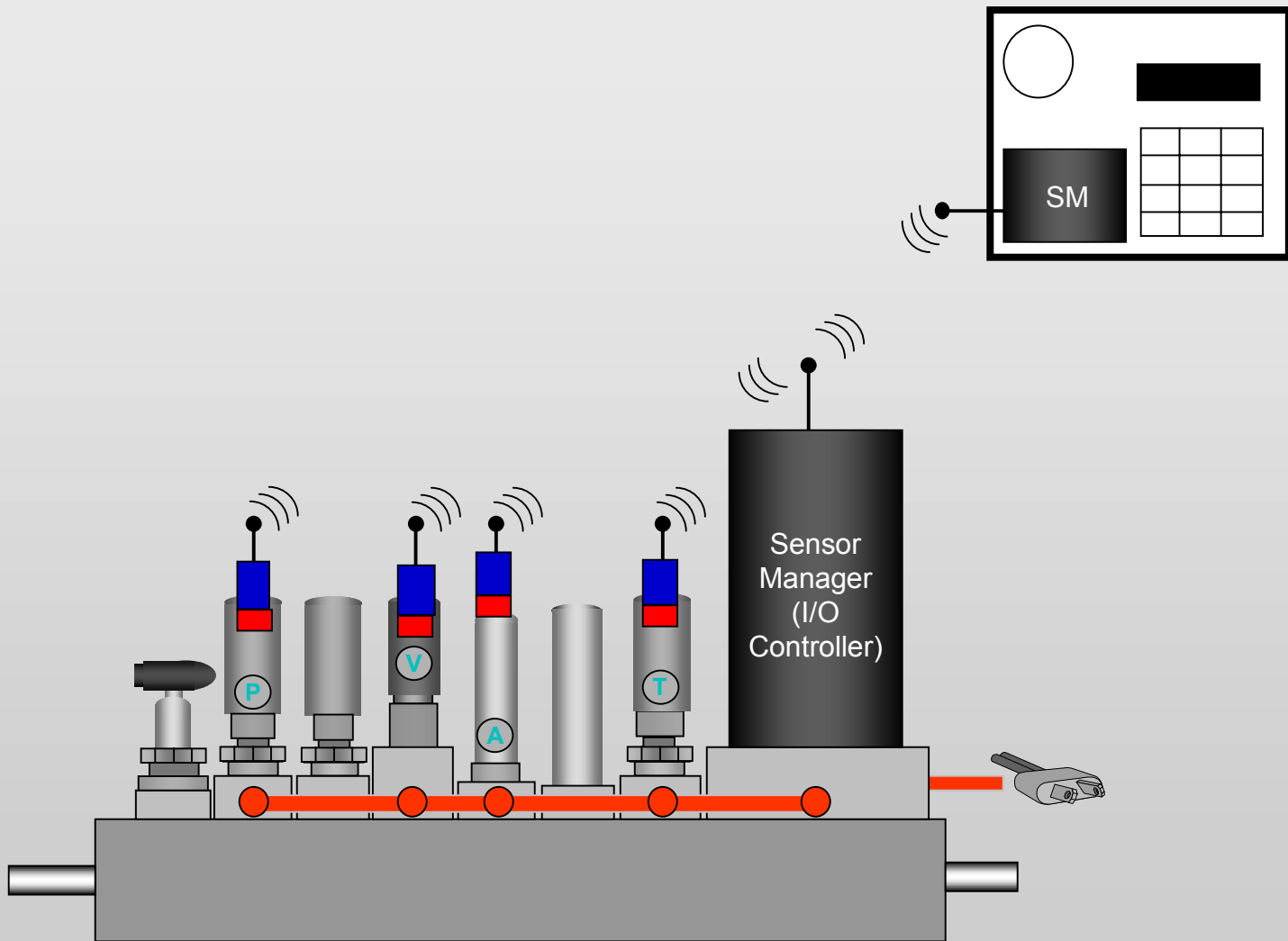

Wired S/A; Wireless IOC

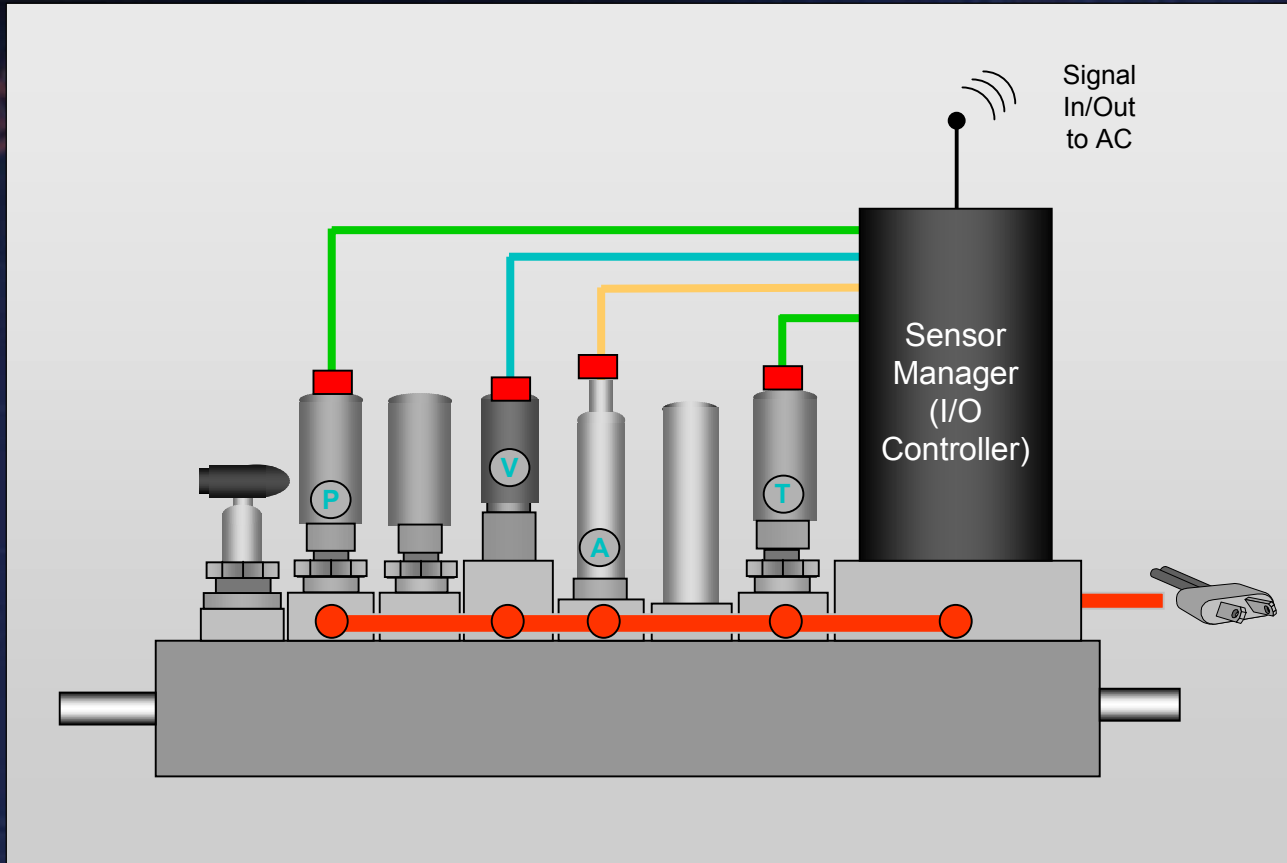

Summary

- Wireless approach seems feasible
- Two basic implementation options
- Most flexible is complete “wireless smart-sensor add-on” for each sensor and actuator and optional wireless I/O controller
- Need to review economics
- Good first step:
 - » SI/O on each sensor / actuator, wired to wireless I/O controller

Crossbow

INTELLIGENT
Sensors
CrossNet
WIRELESS