



NeSSI:

A Vision & A Roadmap

Rob Dubois - Dow Chemical

Jim Tatera - Tatera & Assoc.

Peter van Vuuren - ExxonMobil Chemical

CPAC Spring Session

"the best way to predict the future is to create it"

Outline



■ The Big Vision

- *"Begin with the End in Mind"*

■ Elements of the Vision

- A "Top 10" Shopping List
- Introducing SAM

■ Roadmap

- Elements to Achieve the Vision

NeSSI (An Analytical System)

...Will Look More Like Us!

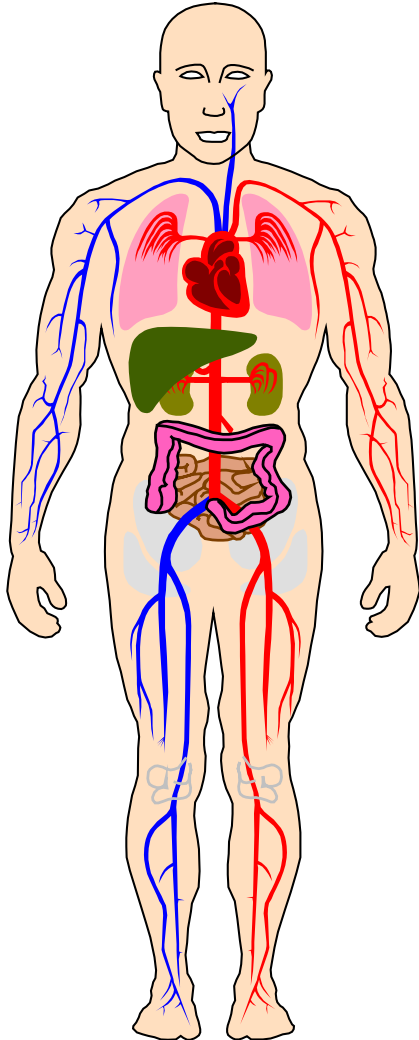

- Single Processor with Overall Control
 - Sensor Analytical Manager or SAM
 - "the brain"
- System will be Multifunctional
 - Equal emphasis on all sensors
- System will be Adaptable
 - Predictive maintenance; self-healing
- Capable of Multivariate Analysis
 - Use multitude of sensors for analysis

NeSSI: *A Shared Vision*

R&D, End Users, Suppliers



- An industrial platform for “lab on a chip” sensors
- a suite of physical and chemical sensors and standard “off the shelf” software
- at the pipe - “analytical transmitter”
- highly reliable - low maintenance
- lower LTCO and capital costs
- profitability for suppliers

The "Top Ten" Shopping List

1. Physical/Diagnostic Sensors

- Flow, Pressure, Temperature
 - gas & liquid services
 - sealed assembly
 - "smart"/digital/plug and play
 - IEEE 1451.2 & Hart
- Substrate diagnostics

CENELAC, UL, CSA, CE
Div/Zone 1, Groups A-D

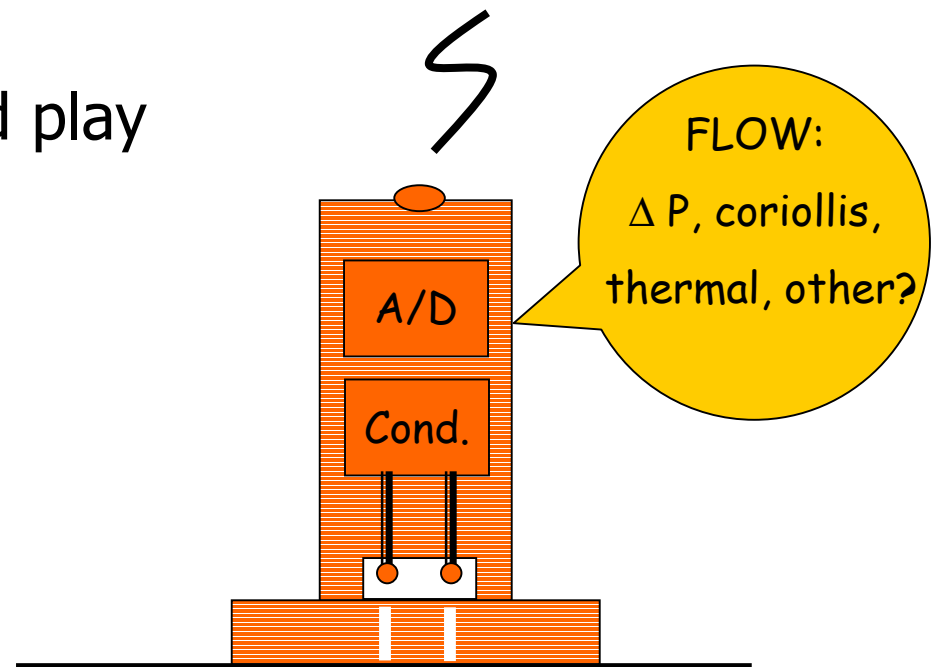

2. On-board Actuators

Solenoid or Motorized Valve



D/A

Vv

Electro-Pneumatic Valve /w integral solenoid valve

D/A

Vv

Instrument Air Supply

CENELAC, UL, CSA, CE
Div/Zone 1, Groups A-D

D/A=digital/analogue converter
Vv=valve

3. Heating-Enclosure

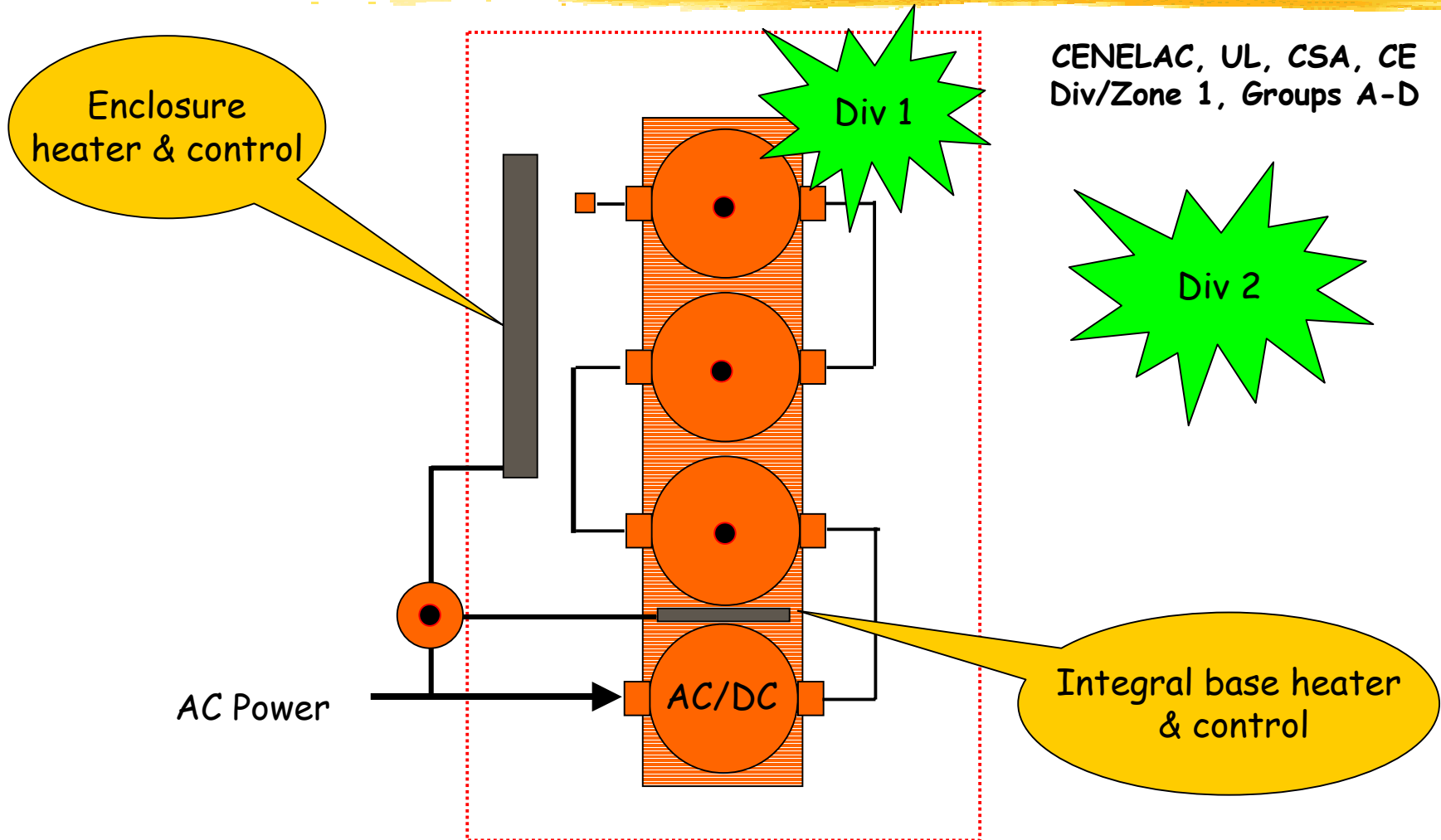

CENELAC, UL, CSA, CE
Div/Zone 1, Groups A-D

4. Power Connection System

- Non-proprietary
 - “plug & socket”

Mini-Power Bus

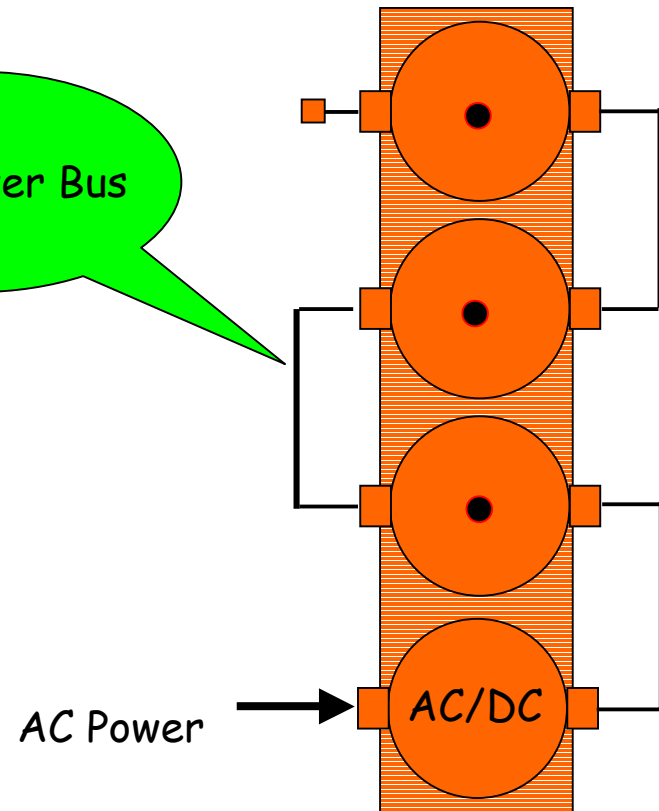

CENELAC, UL, CSA, CE
Div/Zone 1, Groups A-D

5. Signal Transmission

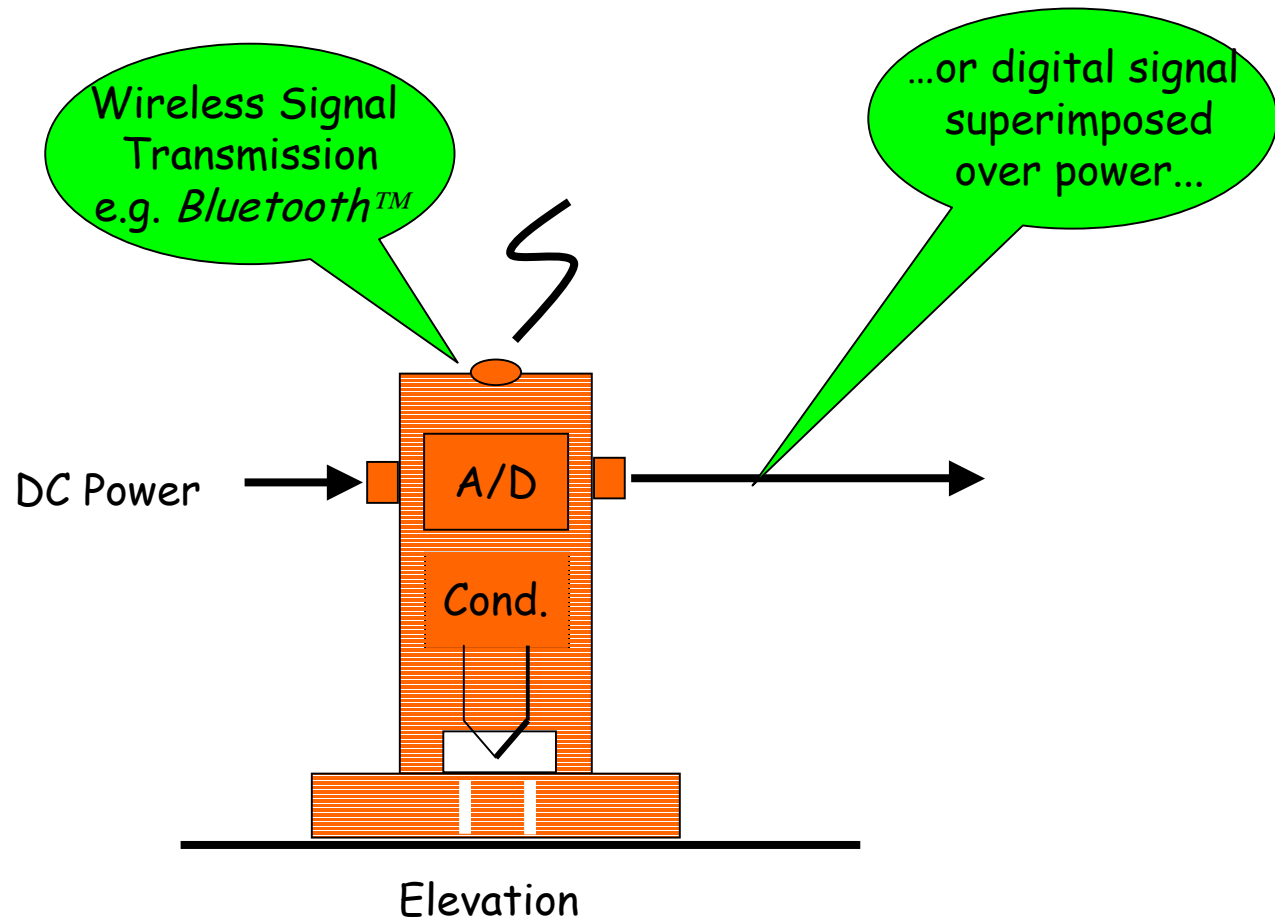

6. Industry Wide - Standard Communication

To the global internet ←

Company Zone LAN - office, environment, Internet -TCP/IP

WS ← Company Workstation

Provides protected access to the Plant LAN →

Keeps external traffic from getting onto this LAN

Interface Router

NT

Analog & Digital I/O

DCS

Plant Control Zone LAN (TCP/IP)

Modbus, Fieldbus or other protocol →

Interface

Provides protected access to the Analyzer LAN →

Keeps Intranet traffic from getting onto this LAN

Interface Router

NT

Note: Only concentrations, diagnostics, control commands to DCS (OPC? Like)

Sensor Analytical Manager

SAM

Analyzer Zone LAN (Large Files e.g. spectra, c'grams, concentrations, diagnostics, control, smart info) LAN (private) TCP/IP

PC

modem

Telephone line

Analytical Sensor

A1

A2

A3

← Analyzers

A4 **F**

F **P**

T

Proprietary Protocol? OR TCP/IP

Miniature/Modular Systems

Dow Chemical Co.

R. J. O'Reilly & Rob Dubois

March 5, 2001

7. Introducing SAM

😊 (Sensor Analytical Manager)

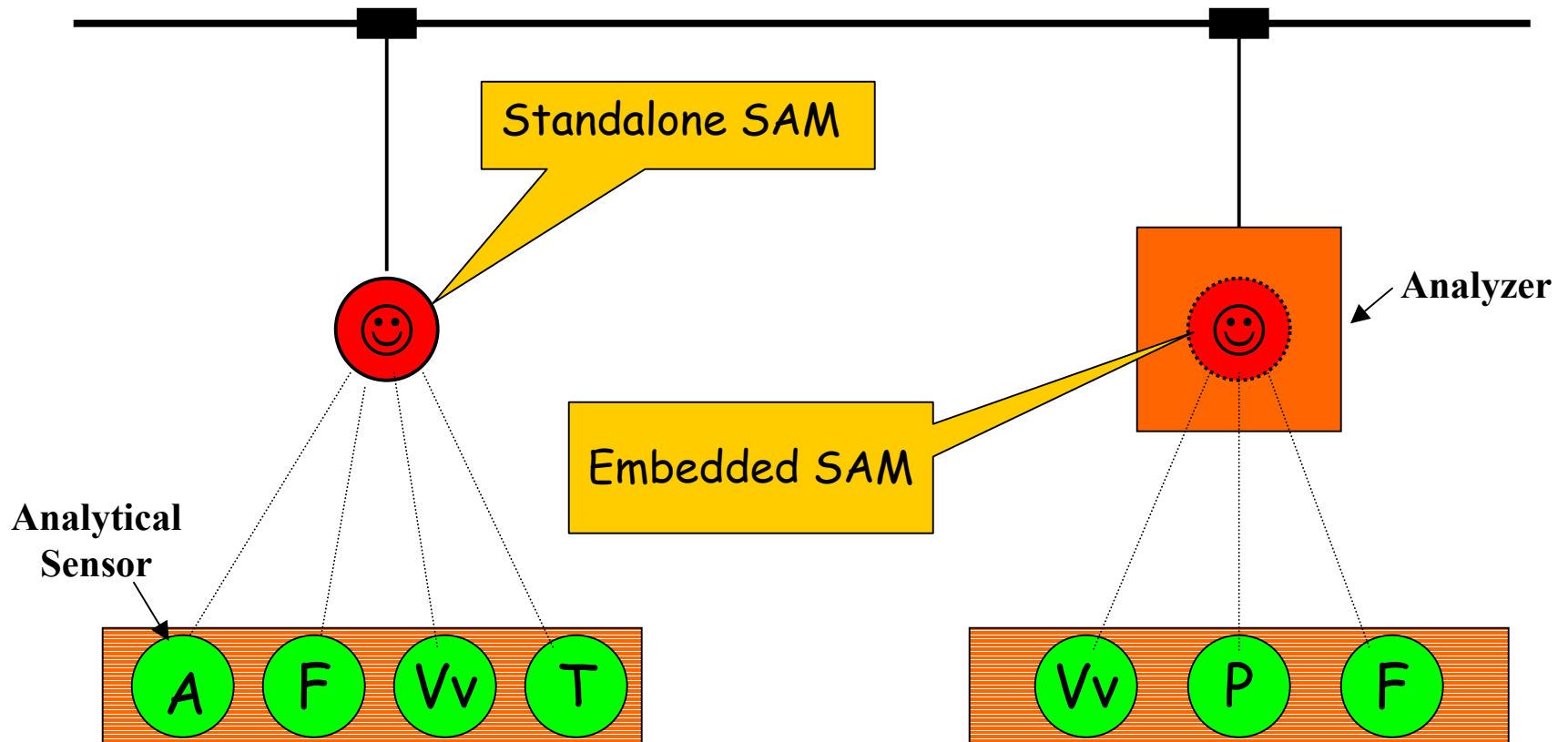

8. Graphical HMI (Human Machine Interface)

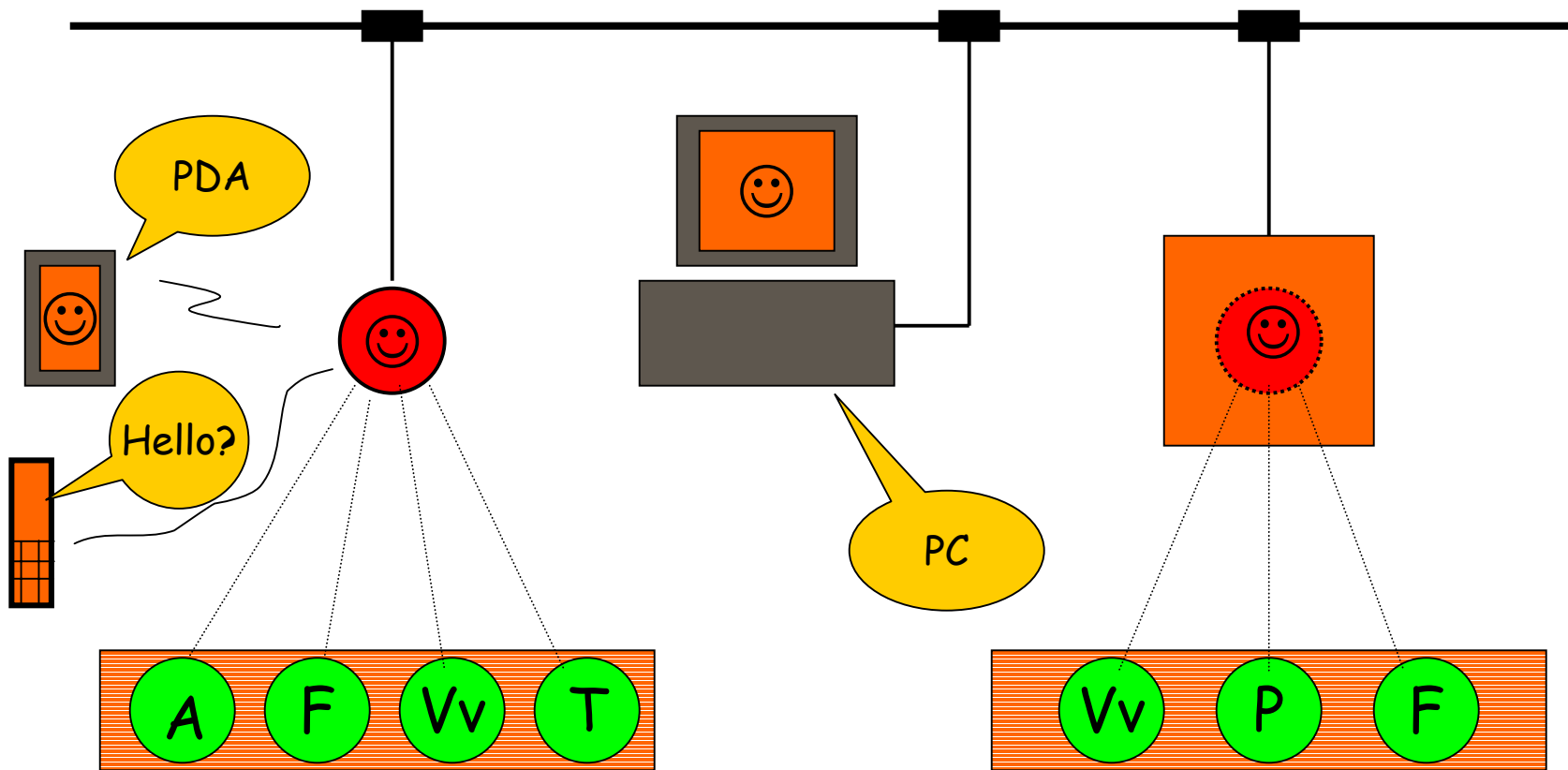

Vv=automatic valve; P=pressure sensor; F=Flow Sensor;
A=Analytical Sensor; T=Temp. Sensor

9. Software Pick-list

- ✓ Zero & span validation
- ✓ Pressure regulation
- ✗ Stream switching
- ✓ Maintenance diagnostics
- ✓ Temperature control
- Global “software objects”
 - interoperability!

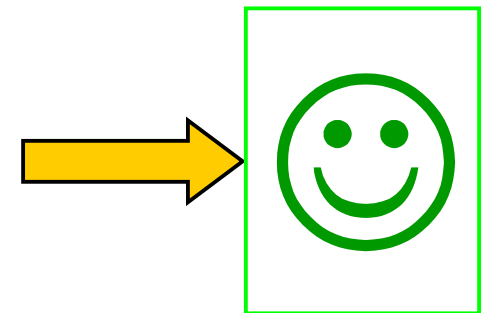

SAM

10. Analytical Sensors (Multiple Analytes)

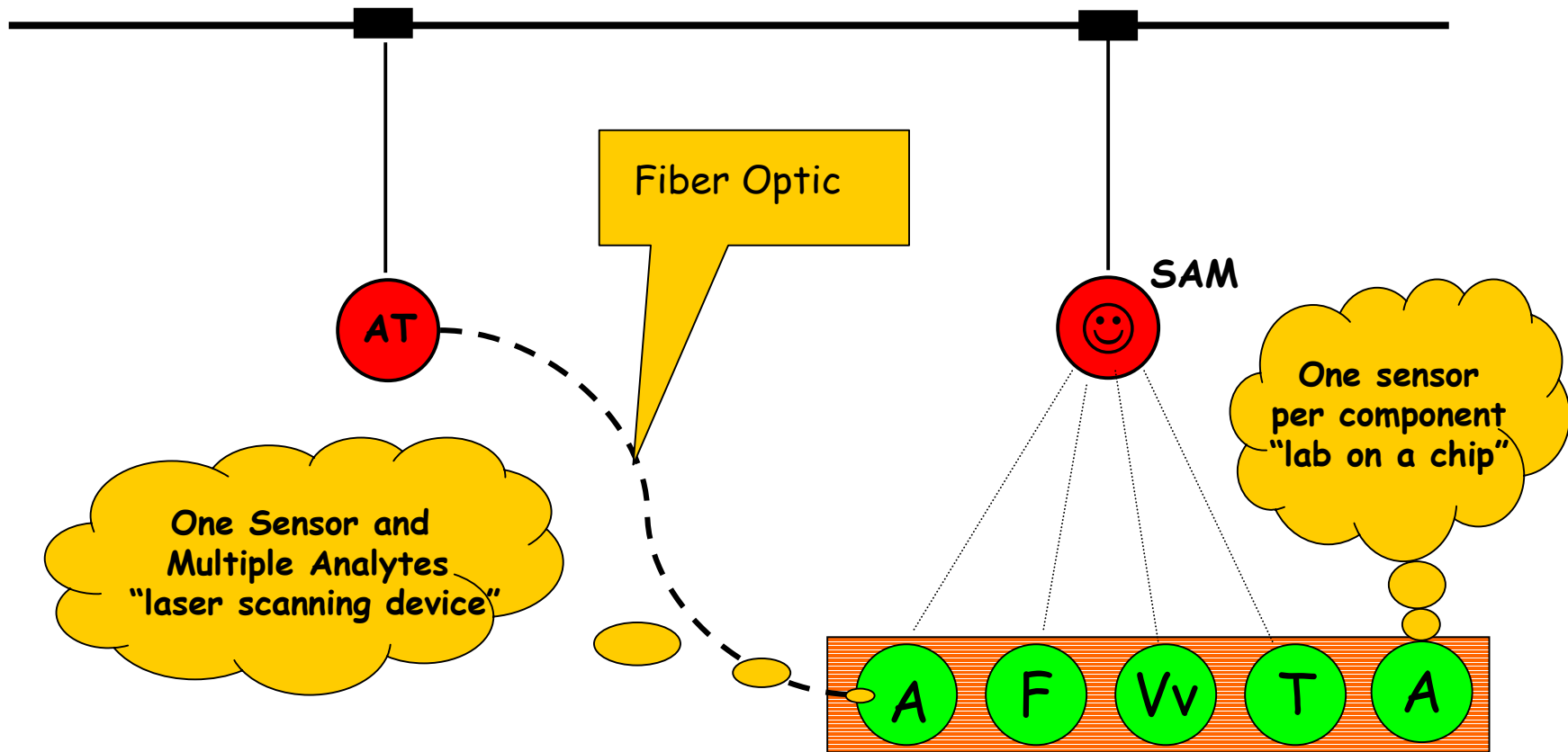
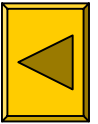

A 5 year Roadmap

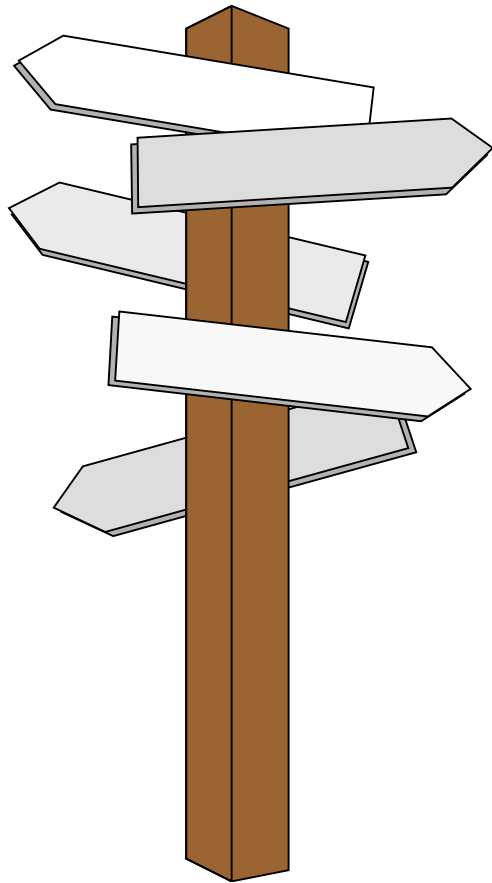

- Elements to Achieve the Vision
 - Make Widely Known
 - Think Global
 - Overcome Legacies
 - Inclusion
 - Industry Wide Testing Program
 - MicroAnalytics

Synergize (some activities)

■ Make Widely Known

- ISA Conf. (2001)
- ISA Analytical Div. (AD)
- IFPAC 2000/2001
- NeSSI CD
- NeSSI User List
- Pittcon sessions
- Workshops

■ Think global

- CPACT presentation (April 2001 - Scotland - J. Gunnell)
- INTERMAC (November - Tokyo, Japan)

Overcoming legacies...



- complex
- expensive
- proprietary
- “big box”
- outdoor oper.
- hi maintenance
- industry: slow to change

Be More Inclusive

- widen the involvement



- Electrify NeSSI [J. Tatera]
 - | Existing/Adapting Technology Subteam (EATS)
- Sensor Functional Specs [K. Creasy]
 - | Functional Analytical Sub Team (FAST)
- SAM - Sensor Analytical Mgr. [R. Dubois]
- MINI-BUS [TBA]
- Connectivity [P. van Vuuren]
- End User test sites & evaluations

CPAC support...



- **Industry Testing Program**
 - | A Lone Ranger/ad hoc approach or test to a common report card??
 - | Suggest an orderly and structured approach
- **Publicize modular component specs**
 - | Sample System Matrix; form factor on CPAC Web Site
- **Closer links with ISA**
- **Sponsor and support NeSSI sub-teams**

Need for a MicroAnalytics Focus Group?



- Desire for MicroAnalytic components
- Step into the NeSSI footprint
- Needed for full development of NeSSI vision...
- Gov't labs, NASA other sensor developers looking for applications provided by NeSSI

Conceptual NeSSI Roadmap

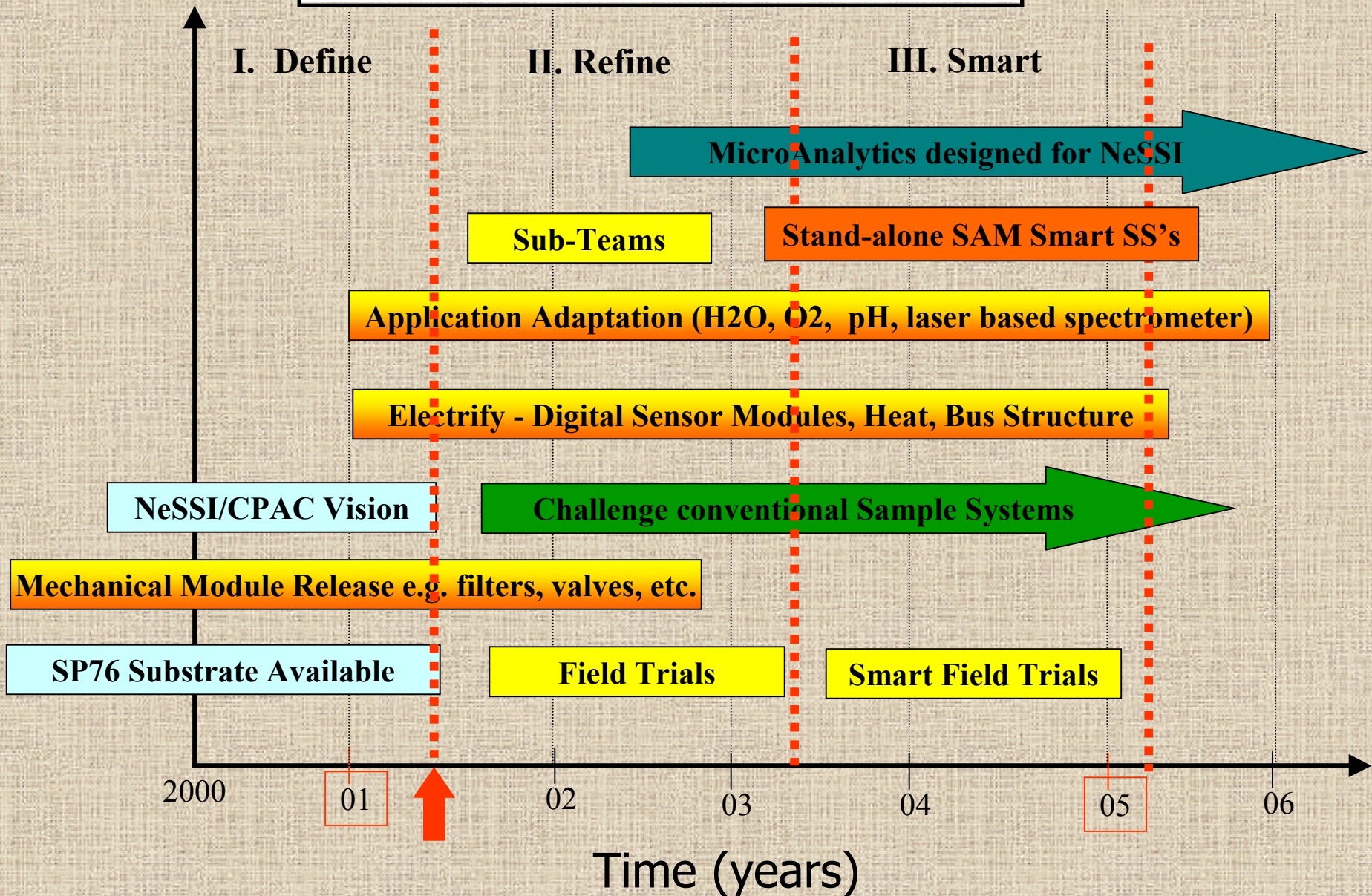

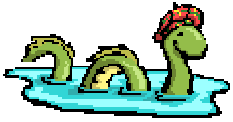

Summary

- NeSSI/CPAC has articulated the Vision
- Substrate & many components available
- Encourage continued commercialization of the Vision
- We all need to collectively demonstrate cost efficiencies & benefits
- End Users must embrace and buy into this revolutionary development