

NeSSI Open Session
September 11th, 2001
Room 311A, Convention Center
1:30 - to about 4:00 PM

- 1:30 PM. Introduction & review of 3 questions.
- 1:45 PM. Discussion/Breakout Groups** [1 hr.]
** Break room into 3 groups. Each group addresses all 3 questions.
- 2:45 Summarize & windup group results.
- 3:00-3:10 Break.
- 3:10-3:30. Report results of the 3 breakout groups to the audience.
[10 minutes each; reported by respective team note-taker]
- 3:30-4:00. Quick update by suppliers of components (5 min each):
Autoflow, Circor International, Kinetics, Parker-Hannifin, & Swagelok.

Question 1. Hazardous/Electrical Area Classification for NeSSI

a. The majority of process analytical systems used by industry are employed in electrical hazardous areas. NeSSI proposes the use of the more stringent Zone/Division 1 (Groups A-D; T4) as the STANDARD electrical classification for ALL NeSSI components. Division/Zone 1 has been specified since it allows a high degree of flexibility (and safety) in placing electrical components in confined enclosures where the potential for leakage of flammable fluids exists. Considering that we want to employ "plug and play" miniature electrical sensors and actuators (both motorized and solenoid), flexible wiring methods, as well as high power heating for both enclosure convection heating and substrate conduction heating:

- **What issues do you see would prevent us from going for Zone/Division 1 classification route?**
- **Is Intrinsic Safety a viable solution?**
- **For the issues presented what do you consider potential solutions (e.g. Protection Methods) or workarounds?**

b. **Who could be potential vendors/people interested** or able to help NeSSI II with supply of miniature electrical components, heating systems, IS/X-proof wiring methods and connectors that would satisfy Division/Zone 1 requirements?

Enclosure/Package

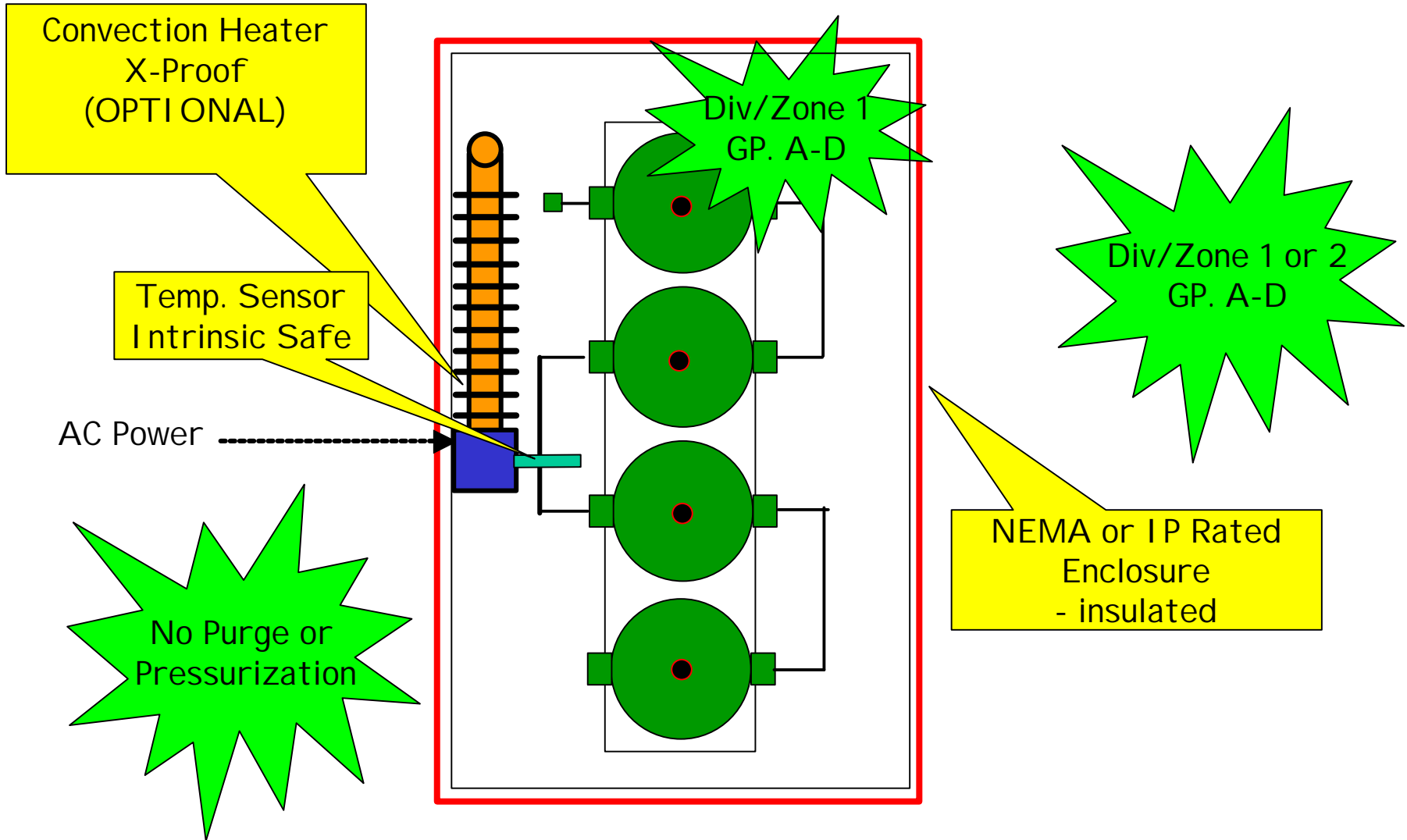

Question 2. A Wired/Unwired Communication Protocol and Sensor Analytical Manager(SAM) for NeSSI

a. NeSSI would like to remove many of the wiring issues associated with 4-20 mA analogue signal transmission. Consequently NeSSI proposes a CAN based bus protocol embedded in each "smart" physical sensor (pressure, temperature, flow) as well as within the electrical actuators.

- **What issues do you see with this approach?**

b. NeSSI also proposes a "wireless" alternative (e.g. Bluetooth, 802.11) for (1) signal communication between the sensors/actuators and the Sensor Analytical Manager (SAM) and (2) between the SAM and the portable HMI device such as a Personal Digital Assistant (PDA).

- **What are the barriers - and ways to overcome - in proceeding down this path?**

c. NeSSI proposes the use of a Sample Analytical Manager (SAM) to (1) serve as a host to a sensor/actuator bus system, (2) a gateway to an Ethernet connectivity system, (3) a wireless gateway to a handheld operating device such as a PDA (4) a repository of "industry standard" repetitive software functions which are common to the operation of an analyzer sample system.

- **What do you see as a barrier to implementing SAM?**
- **Who, in your opinion, should define applets and supply SAM?**
- **What do you see as a reasonable cost for SAM?**

SAM does 4 jobs!

HMI Interface - Field

- Graphical
- Wireless
- e.g. Bluetooth™, 802.11

Gateway to an Ethernet LAN

- OPC perhaps

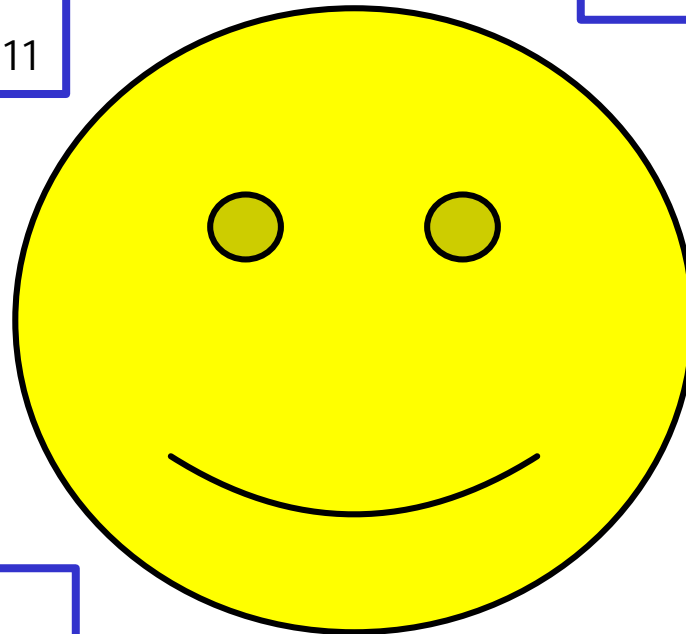

**Host to a
Sensor/Actuator Bus**

Software Applets for

Sample System
Repetitive Tasks
(Industry Common)

Standalone “SAM” with Wired Sensor/Actuator Bus

- *IEC Ex ib intrinsically safe*
- *Leverage FISCO power concept*
- *Standard Plug & Play Conn.*
- *DeviceNet or SDS*

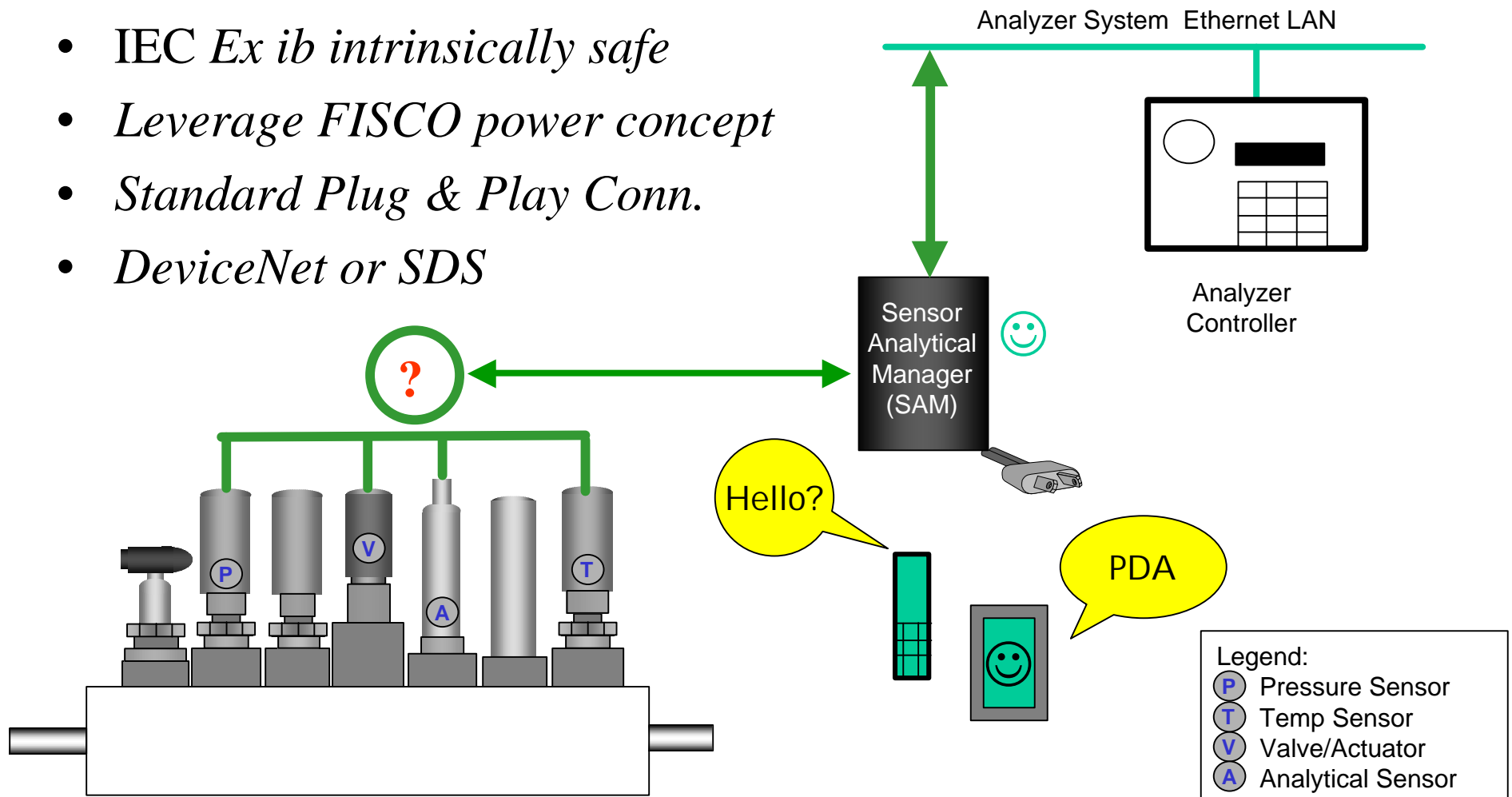

Question 3. Sensor/Actuator Distributed Functionality for NeSSI

a. NeSSI proposes the use of encapsulated miniature sensors and actuators with digital embedded, A/D and communication chips.

- What features should these sensors and actuators have, which, in your opinion would make them SMART?
- Other than Pressure, Temperature, Flow (and Actuation) do you think any other sensors should be incorporated into the substrate?
- What price range do you think the market would bear for these sensors?
- Who are some potential developers/supplier who can or be interested in providing...
 - chemical (miniature analytical sensors) and...
 - physical sensors...suitable for the NeSSI SP76 substrate.

Conceptual Sensor f

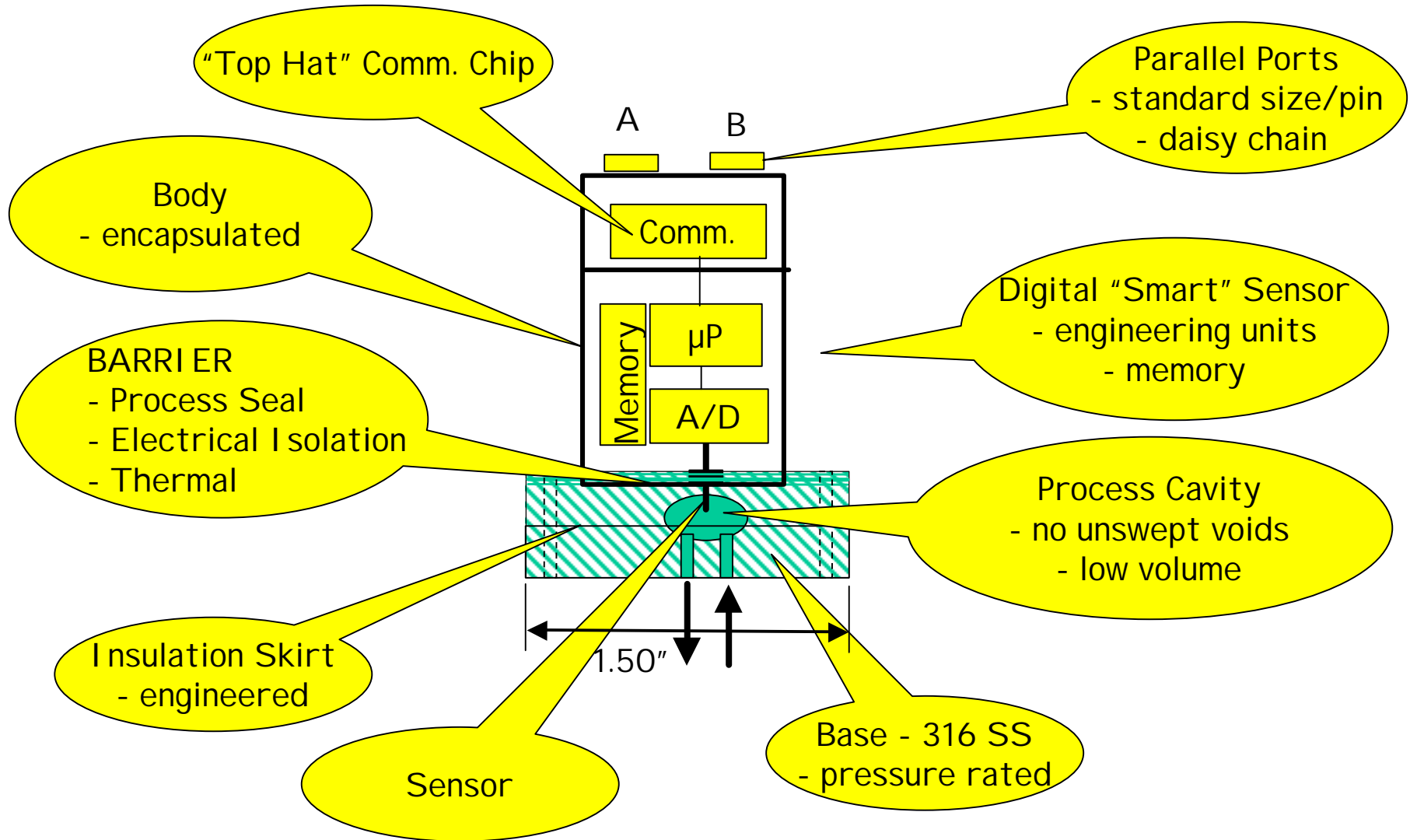

Conceptual “Combo” Valve

